

Note: The most current version of these instructions can be found online at www.grahamfield.com

Tools needed: 5/8 wrench, M6 hex key (included)

IMPORTANT SAFETY INFORMATION: PLEASE READ

- ⚠ WARNING: Important! Read and understand these instructions before assembling or using the GF8903P Overbed Table. If you do not understand any part of these instructions, contact a healthcare professional for direction in the use of this product. If the overbed table is not properly assembled and adjusted, personal injury and/or damage to the overbed table could result.**
- ⚠ WARNING: If components are damaged or missing, contact your dealer immediately. DO NOT use substitute parts. Use only Lumex® replacement parts. Non-Lumex® replacement parts could cause personal injury and/or damage to overbed table.**
- ⚠ WARNING: GF Health Products, Inc. assumes no responsibility for any damage or injury caused by improper assembly or use of this product.**

UNPACKING

Check for any obvious damage to the carton or its contents. If damage is evident, DO NOT USE. Contact carrier / distributor for further instruction.

ASSEMBLY

- ⚠ WARNING: The column is telescoping and spring-loaded — handle with care during assembly. DO NOT disassemble the column; this could cause serious personal injury.**
1. Place table top upside down on a level surface as shown at right.
 2. Position column bracket above table top bracket as shown at right, with holes matched, and lower column onto table top. Insert socket head cap screws through column bracket into table top bracket as shown. Use M6 hex key to tighten the screws.
 3. Place the base upside down above the column as shown at right. Install the two large hex bolts through the bolt plate, base, and into column end as shown. Use 5/8 wrench to tighten the bolts.
 4. Note position of casters, facing away from table top, with the two locking casters at the column end of the base. Insert caster bolts into base as shown at right. Screw casters in securely.
 5. TURN THE TABLE UPRIGHT and place it on the floor.

- ⚠ WARNING: Ensure that the table is assembled as described, and that all components are securely attached, before use.**

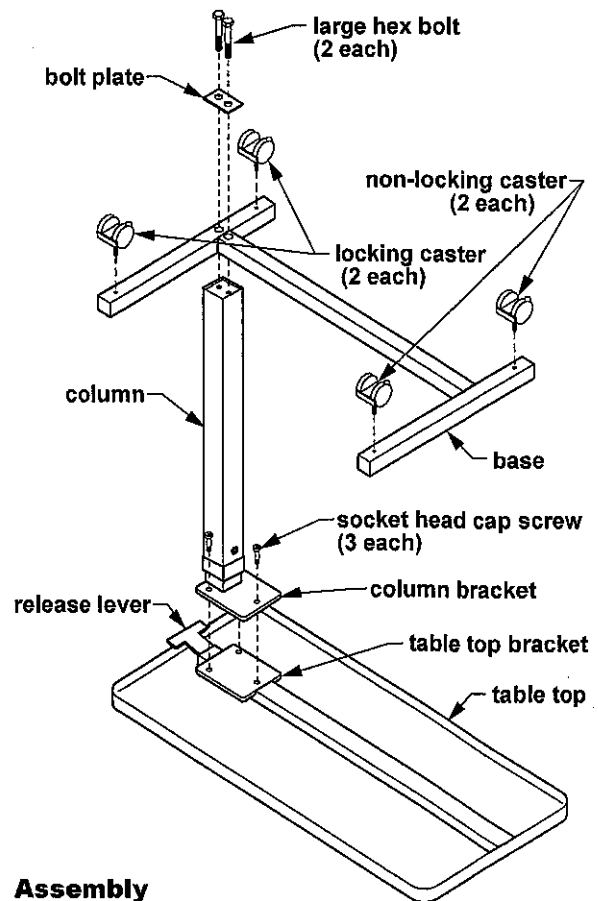

OPERATION

⚠ **WARNING: Do not lean on the suspended end of the table top; this may cause the table to tip.**

⚠ **WARNING: The table supports up to 22.7 kg (50 lb) of dispersed weight. Do not exceed this limit.**

Raise the table top

Table height is adjustable from 72 cm to 106 cm (28.3" to 41.7"). To raise the table top, apply light pressure upward at any point on bottom of table top and stop when the table top has reached the desired height.

Lower the table top

With one hand, squeeze the release lever and table top edge together and push the table top down until it has reached the desired height. The table top will lock into place when the lever is released.

Lock and unlock casters

The two column-end casters have step-on locks. Step on the locks to lock the casters; pull the locks up to unlock the casters.

MAINTENANCE

Check the fit and tightness frequently of all fasteners, and tighten as necessary, to ensure that the table is securely assembled.

Cleaning

1. To clean: Gently wipe the table with a soft, clean, damp cloth.

▲ **CAUTION: Do not use cleansers that could damage the table's finish.**

2. To wash more thoroughly: Clean with mild soap and water.

3. Dry table with a clean, soft cloth.

WARRANTY

GF Health Products, Inc. ("Graham-Field") offers a one-year limited warranty against manufacturer's defects on the Lumex® GF8903P Overbed Table. If a product is deemed to be under warranty, GF Health Products, Inc. shall provide, at its option, (1) replacement of any defective part or product or (2) a credit of the original selling price made to GF Health Products, Inc.'s initial customer. The warranty does not include any labor charges incurred in replacement part(s) installation or any associated freight or shipping charges to GF Health Products, Inc.

The warranties contained herein contain all the representations and warranties with respect to the subject matter of this document, and supersede all prior negotiations, agreements and understandings with respect thereto. The recipient of this document hereby acknowledges and represents that it has not relied on any representation, assertion, guarantee, warranty, collateral contract or other assurance, except those set out in this document.



GRAHAM-FIELD
www.grahamfield.com

GF Health Products, Inc. is not responsible for typographical errors. Packaging, warranties, products and specifications are subject to change without notice. Graham-Field and Lumex are registered trademarks of GF Health Products, Inc.

© 2011 GF Health Products, Inc. • 2935 Northeast Parkway • Atlanta, GA 30360 • tel 770-368-4700 • fax 770-368-2386